

Book-style EMC/RFI Filter for regenerative drive application

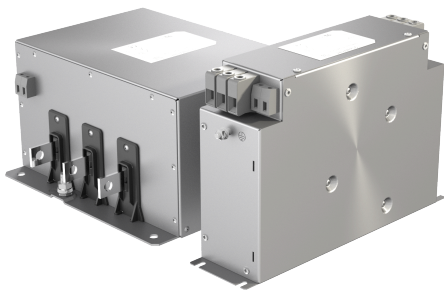

- Designed for usage together with LCL filter
- Easy design in with system approach documentation
- Footprint space-saving book-style housing
- Thermal shutdown capability
- Solid safety connector blocks
- Versions with low leakage current

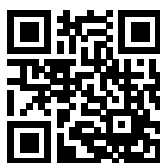

Performance indicators

Attenuation performance



Rated current [A]

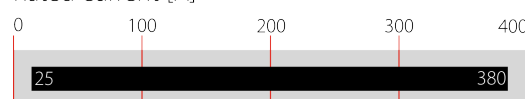

Technical Specifications

Maximum continuous operating voltage	3x 530/305 VAC
Operating frequency	DC to 50/60 Hz
Rated currents	25 to 380 A @50°C
Overload capability	6x rated current for 1 sec, once per hour 1.6x rated current for 1 minute, once per hour
Climatic class	40/100/21 acc. to IEC 60068-1
Temperature range (operation and storage)	-40°C to +100°C (with current derating >50°C)
High potential test voltage	P -> E 2550 VDC for 2 s P -> P 2550 VDC for 2 s TS/TS' -> E 2550 VDC for 2 s TS/TS' -> 3P 2550 VDC for 2 s
Pollution degree	2 acc. IEC 60664-1
Overvoltage category	III acc. IEC 60664-1
Surge withstand	2kV (P-P) / 4kV (3P - E) acc. to IEC 6100-4-5
Altitude	up to 2000m no derating applies. Above 2000m derating acc. to IEC 60664-1 applies
Design corresponding to	UL 60939-3, IEC 60939-3
Compliance with insulation requirement	> 1MΩ acc. to IEC 60204-1
Protection category	IP 20 (terminal block versions) and IP00 (busbar versions) acc. to IEC 60529-1
Vibration and shock	3M4 (operation) acc. to IEC 60721-3-3
Flammability corresponding to	Terminals: UL 94 V-0
MTBF	> 300,000 hours

Approvals & Compliances



Features and Benefits

- FN 3840 series of filters provides state-of-the-art EMI attenuation based on an innovative filter topology. They help to ensure compliance with Class C2 or even C1 limits.
- The filters are built to fit perfectly to regenerative drive applications with LCL filters
- Internal thermocouples ensure reliability and thermal shutdown capabilities
- The slim book-style shape allows a convenient and space-saving installation next to inverters, converters or motor drives.
- The filters offer very high saturation performance, bundled with best EMI performance
- Fulfills the requirements in IEC/EN 61800-5-1 for electric strength, clearance and creepage
- Fulfills the requirements in IEC/EN 60204-1 for insulation resistance, electric strength, clearance and creepage
- Fulfills the requirements in IEC/EN 62477-1 for electric strength, clearance and creepage

Typical Applications

- Regenerative drives in combination with LCL filters
- Active infeed converter (AIC)
- Active front end (AFE) variable frequency drives (VFD)
- Three-phase variable speed drives (VSD) and power drive systems (PDS)
- Renewable Energy
- Machine tool and machinery equipment
- Process automation equipment

Typical electrical schematic

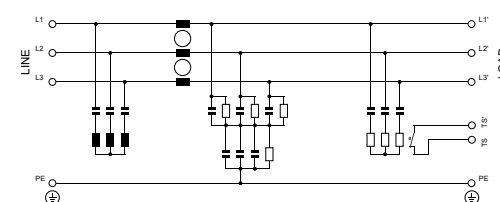

Filter Selection Table

Filter	Rated current @ 50°C [A]	Typical drive power rating* [kW]	Leakage current** @ 530 VAC/50 Hz [mA]	DC Resistance @ 25°C [mOhm]	Typical Power Dissipation*** (Cu + Damping) [W]	Terminal Type	Weight [kg]	Thermal Switch**** Switching Temp. [°C]
FN3840-25-33-C35-R65	25	15	4.3	9.5	22 (18 + 4)	-33	2.5	180
FN3840-50-53-C35-R65	50	30	4.3	5	43 (38 + 5)	-53	3.5	180
FN3840-80-34-C45-R65	80	45	7.7	1.5	40 (29 + 11)	-34	5.7	180
FN3840-160-40-C45-R65	160	90	7.7	0.4	40 (31 + 9)	-40	7.9	180
FN3840-250-99-C2835-R67	250	150	10.7	0.1	26 (19 + 7)	-99	4.3	150
FN3840-380-99-C2835-R67	380	200	10.7	0.07	33 (28 + 5)	-99	4.5	150

* Typical power rating at 400 VAC with cos phi=0.85. The exact value depends upon the efficiency of the drive, the motor and the entire application.

** Standardized calculated leakage current acc. IEC 60939 under normal operating conditions.

*** Losses on copper (conductor) plus damping resistor losses. For further details on damping resistor losses please refer to page 4: Damping resistor losses vs switching frequency

**** Normally closed thermal protector switch, 250VAC / 24VDC, 6.3A (with cos phi 0.6); reverse switching temperature = switching temp - 50K.

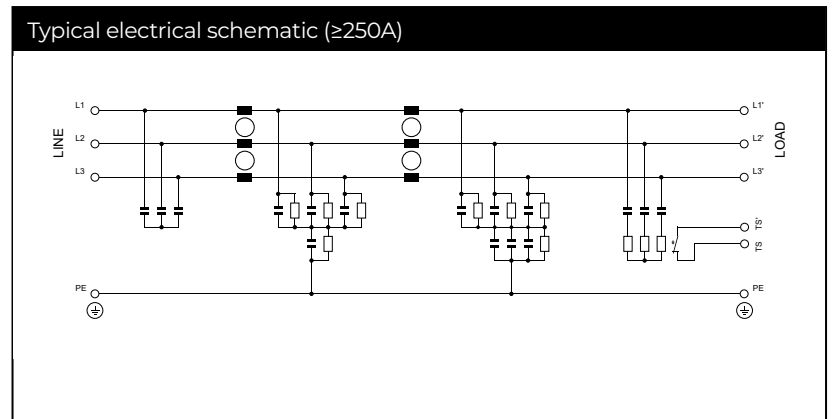
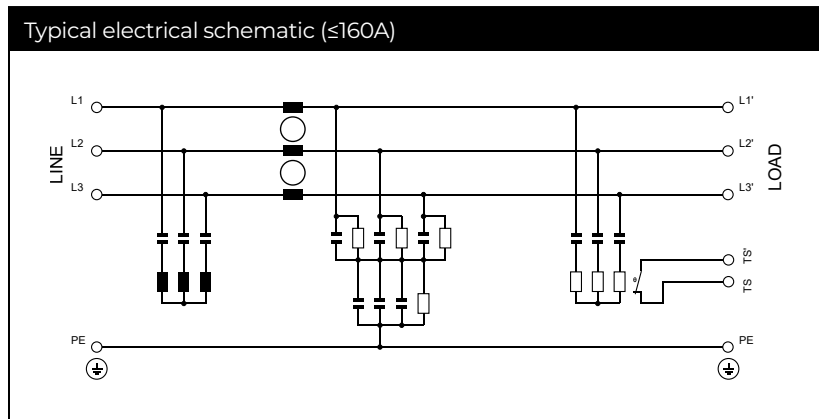

Tolerances apply: L +50%/-30% , C ±20%, R ±10%

Typical Filter Attenuation

Per CISPR 17: symmetrical 50 Ω/50 Ω -> Differential Mode (DM); asymmetrical 50 Ω/50 Ω -> Common Mode (CM)

FN3840-25-33-C35-R65

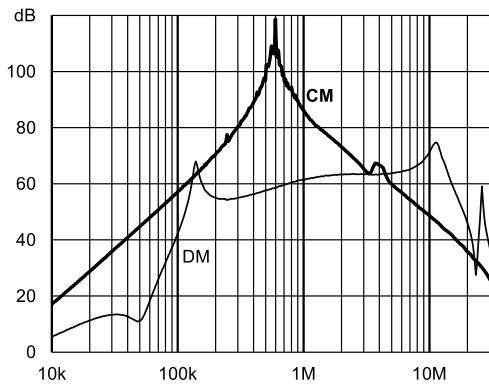

FN3840-50-53-C35-R65

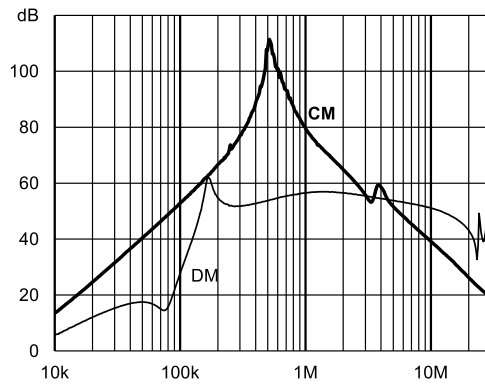

FN3840-80-34-C45-R65

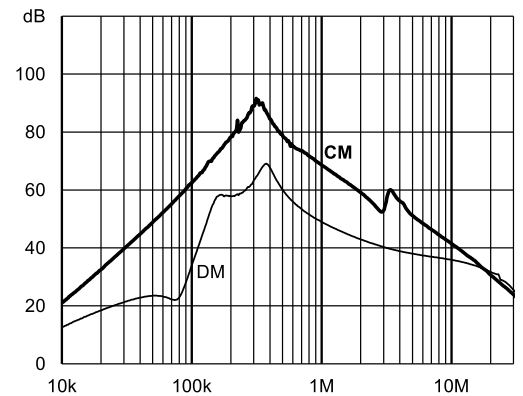

FN3840-160-40-C45-R65

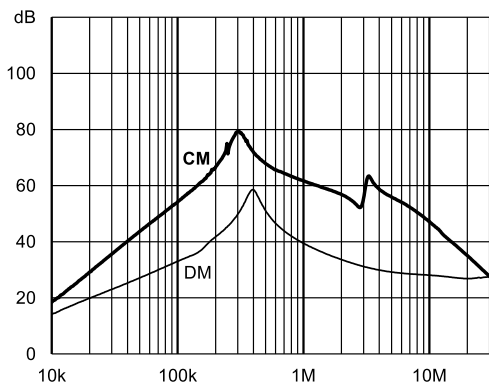

FN3840-250-99-C2835-R67

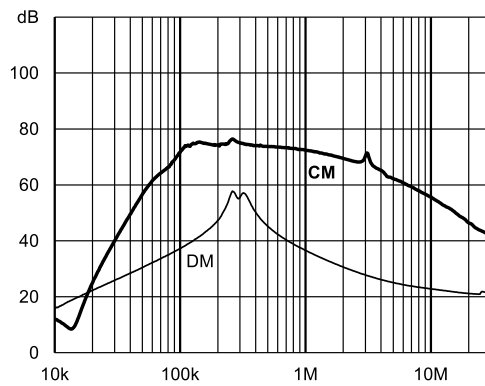

FN3840-380-99-C2835-R67

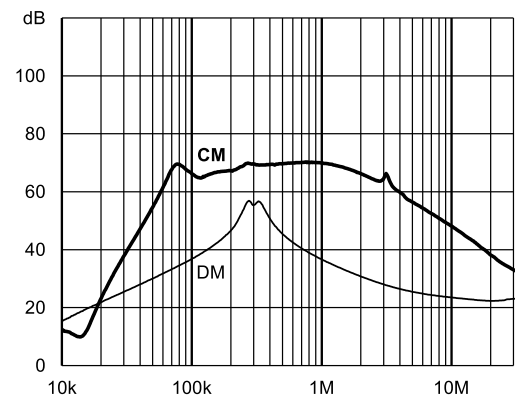

Typical Application

System diagram of an Active Front End (AFE) application

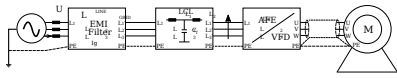

Frequency Response

Frequency response at different values of the grid inductance. The grid inductance is calculated with details mentioned at each graph. Each figure represents the normalized admittance transfer function between the grid current, i_g , and the converter voltage u_s . At low frequencies, the equivalent admittance is inversely proportional to the total DC resistance of the grid, and EMI and LCL filters ($R_{GRID}+R_{EMI}+R_{LCL}$), which is dominated mainly by the LCL filter R_{LCL} .

FN3840-25-33-C35-R65

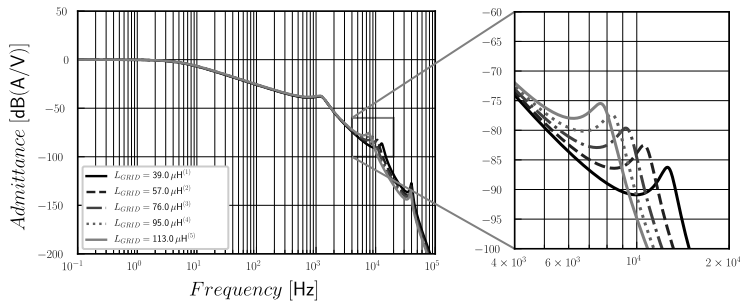

400 VAC/50 Hz, 250 kVA trafo with uk of (1) 1%, (2) 2%, (3) 3%, (4) 4%, (5) 5% and 50m cable.

FN3840-50-53-C35-R65

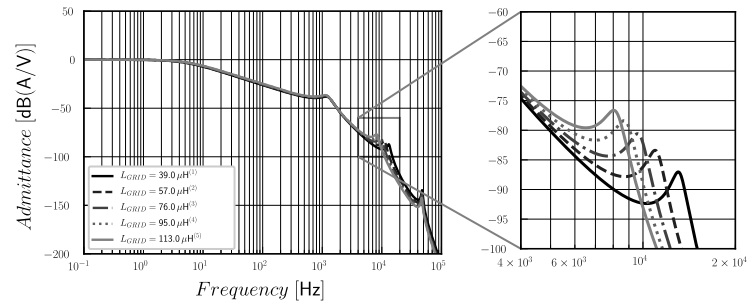

400 VAC/50 Hz, 250 kVA trafo with uk of (1) 1%, (2) 2%, (3) 3%, (4) 4%, (5) 5% and 50m cable.

FN3840-80-34-C45-R65

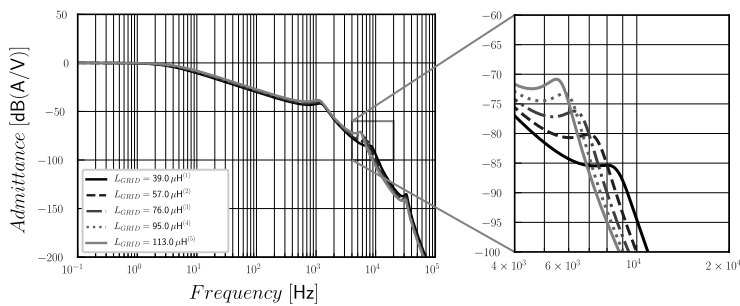

400 VAC/50 Hz, 250 kVA trafo with uk of (1) 1%, (2) 2%, (3) 3%, (4) 4%, (5) 5% and 50m cable.

FN3840-160-40-C45-R65

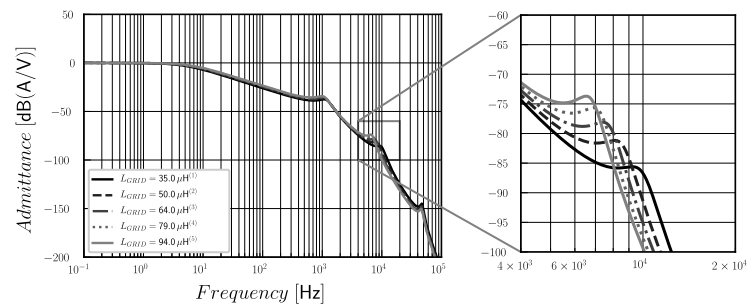

400 VAC/50 Hz, 315 kVA trafo with uk of (1) 1%, (2) 2%, (3) 3%, (4) 4%, (5) 5% and 50m cable.

FN3840-250-99-C2835-R67

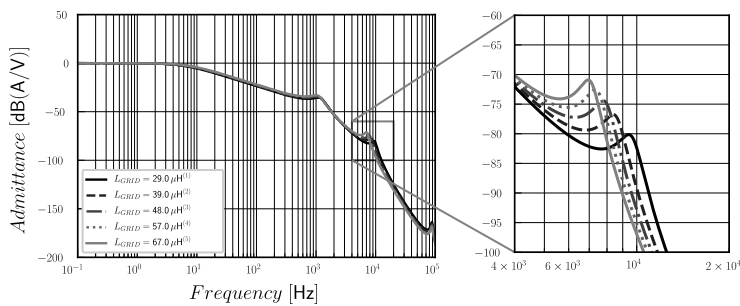

400 VAC/50 Hz, 500 kVA trafo with uk of (1) 1%, (2) 2%, (3) 3%, (4) 4%, (5) 5% and 50m cable.

FN3840-380-99-C2835-R67

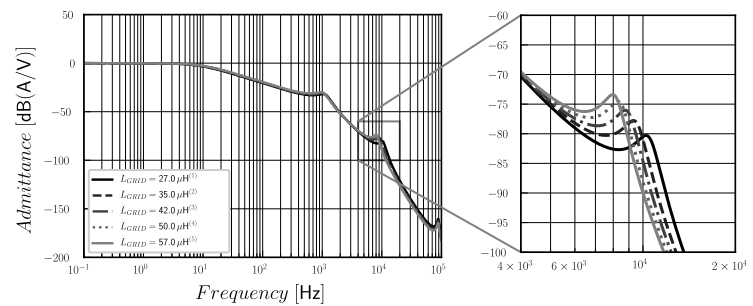

400 VAC/50 Hz, 630 kVA trafo with uk of (1) 1%, (2) 2%, (3) 3%, (4) 4%, (5) 5% and 50m cable.

Damping Resistor Losses Vs Switching Frequency

Typical losses at different values of the AFE-LCL L1 inductor with rated voltage (530 VAC/60 Hz) and differing grid inductance. (25A->95µH; 50A->95µH; 80A->95µH; 160A->79µH; 250A->57µH; 380A->50µH).

The highlighted gray area represents a non-operating area. Operating the filter in this area may cause overheating and damage to the filter, and may activate the temperature switch.

FN3840-25-33-C35-R65

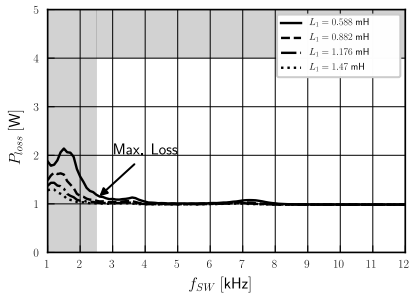

FN3840-50-53-C35-R65

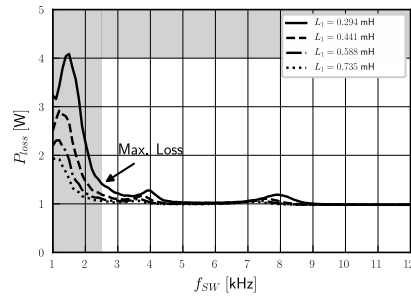

FN3840-80-34-C45-R65

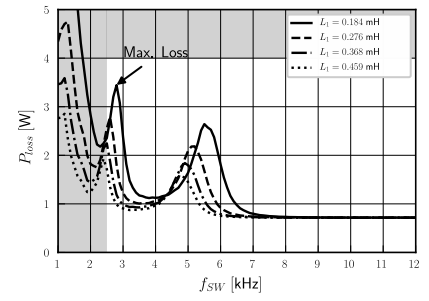

FN3840-160-40-C45-R65

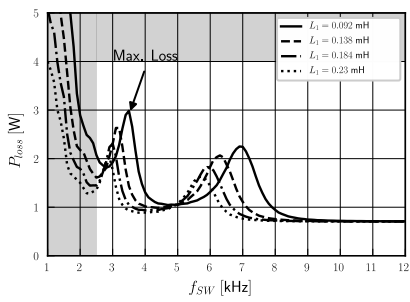

FN3840-250-99-C2835-R67

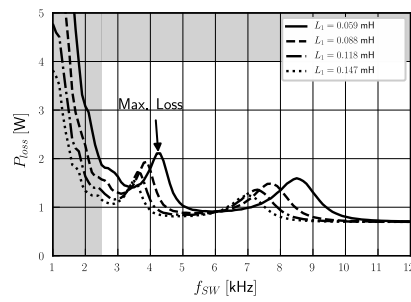

FN3840-380-99-C2835-R67

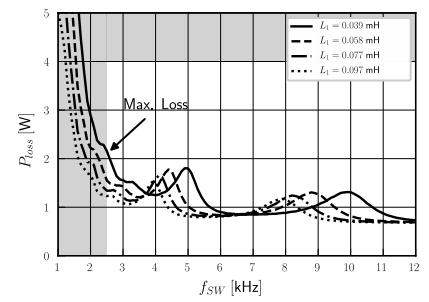

Mechanical Data For Filters With Terminal Blocks

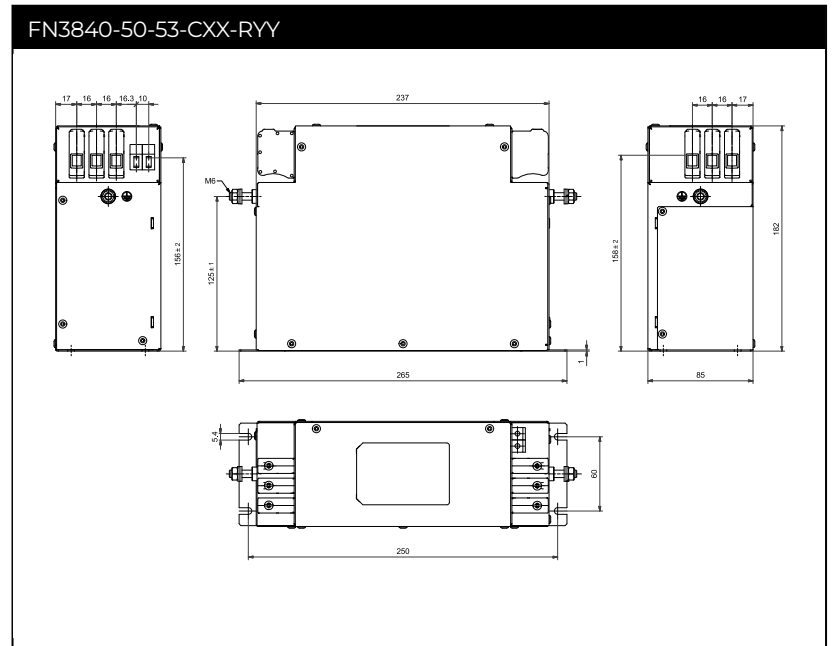
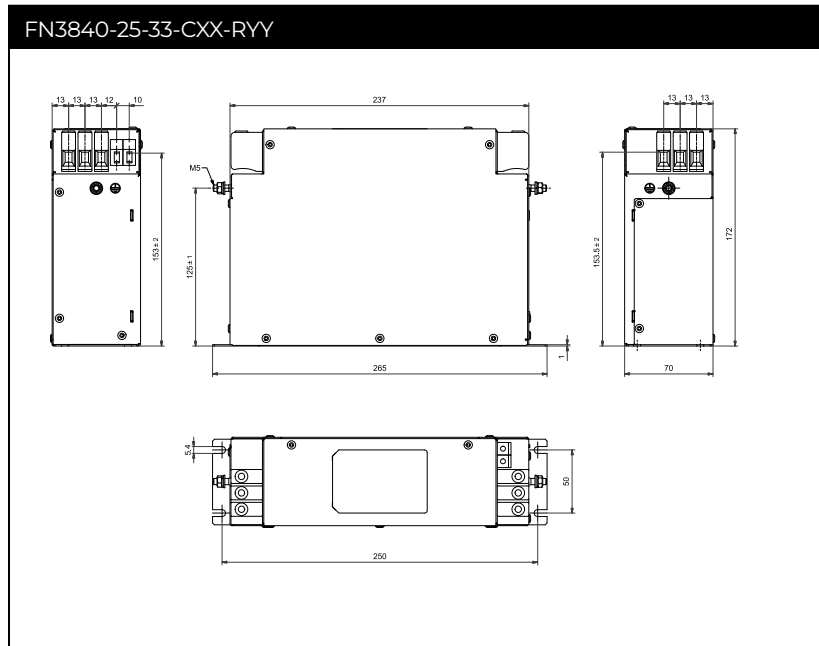

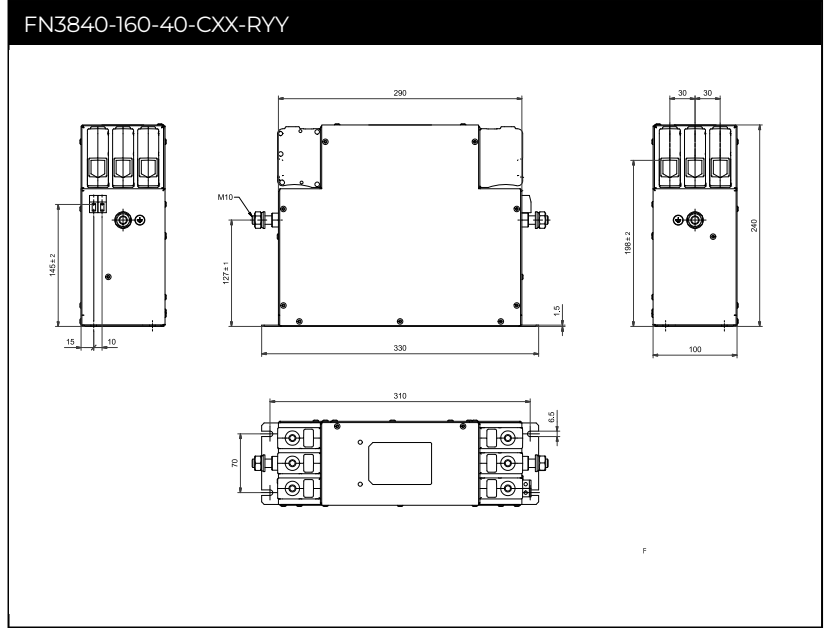
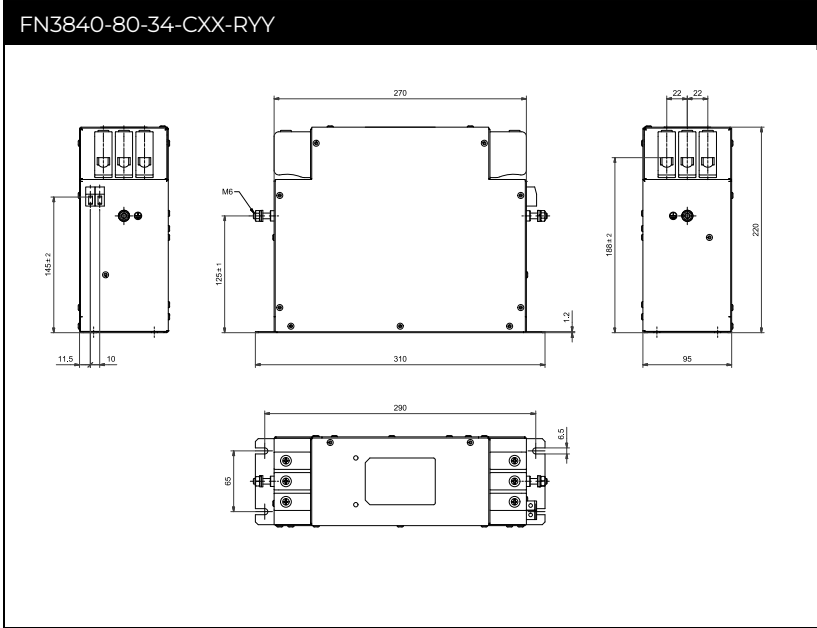

Filter Input/Output Connector Cross Sections

	-33	-53	-34	-40	Thermal Switch	PE	PE	PE	PE
						M5	M6	M8	M10
Solid wire	0.5-16 mm ²	0.5-16 mm ²	6-35 mm ²	25-95 mm ²	0.2-6 mm ²				
Flex wire	0.5-10 mm ²	0.5-16 mm ²	6-25 mm ²	25-95 mm ²	0.2-4 mm ²				
Flex wire AWG	AWG 22-6	AWG 20-4	AWG 6-2	AWG 4-4/0	AWG24-AWG10				
Recommended torque	1.5-1.8 Nm	2.0-2.3 Nm	4.0-4.5 Nm	17-20 Nm	0.7 -0.8mm	2.0-2.2 Nm	3.5-4.0 Nm	8.0-9.0 Nm	15-17 Nm

Please visit www.schaffner.com to find more details on filter connectors.

Mechanical Data For Filters With Busbar Connection

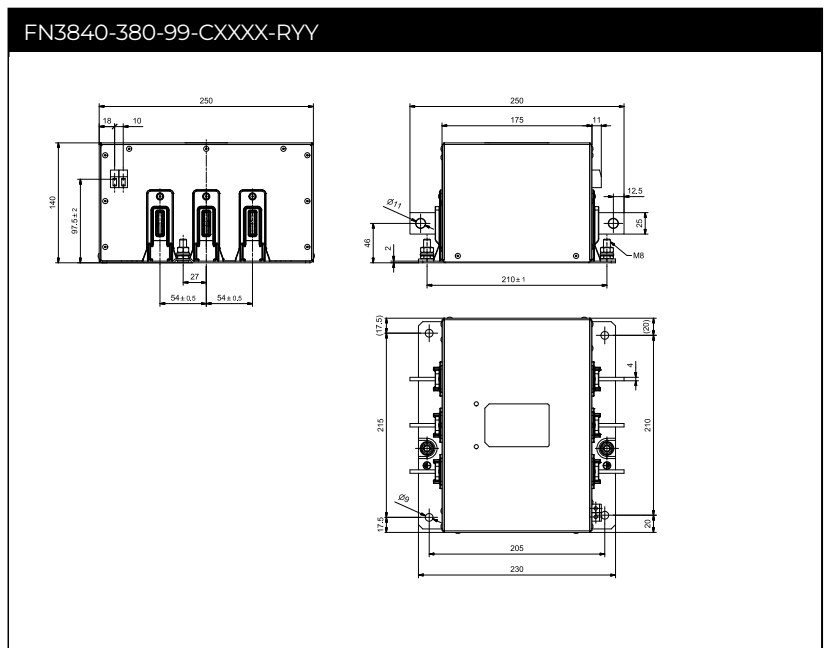
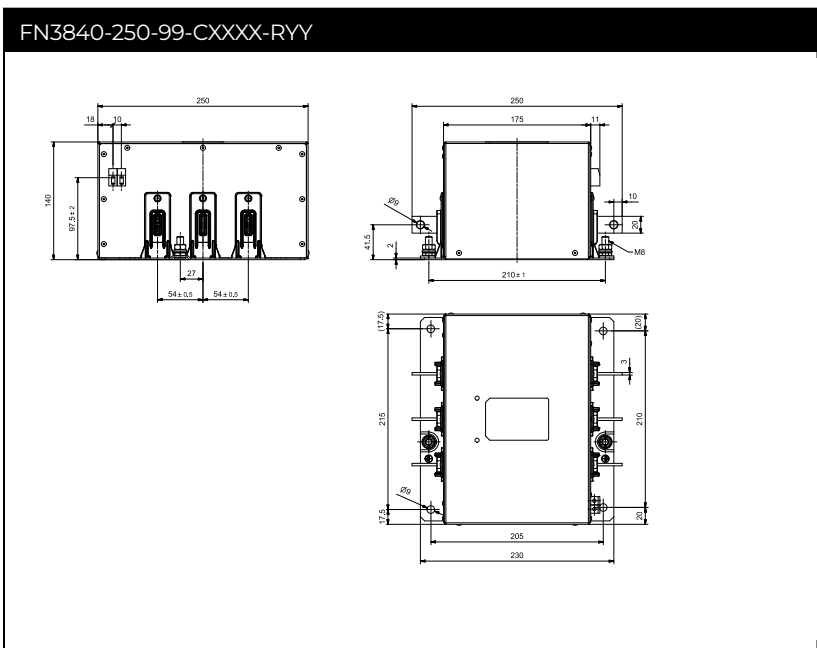

Headquarters, Global Innovation and Development

Switzerland

Schaffner Holding AG

Industrie Nord
Nordstrasse 11e
4542
Luterbach
+41 32 681 66 26
info@schaffner.com

Sales and Application Centers

China

Schaffner EMC Ltd. Shanghai

T20-3 C, No 565 Chuangye Road, Pudong district
201201
Shanghai
+86 2138139500
cschina@schaffner.com

Finland

Schaffner Oy

Sauvonrinne 19 H
8500
Lohja
+358 50 468 7284
finlandsales@schaffner.com

France

Schaffner EMC S.A.S.

16-20 Rue Louis Rameau
95875
Bezons
+33 1 34 34 30 60
francesales@schaffner.com

Germany

Schaffner Deutschland GmbH

Schoemperlenstrasse 12B
76185
Karlsruhe
+49 721 56910
germanysales@schaffner.com

India

Schaffner India Pvt. Ltd

Regus World Trade Centre
WTC, 22nd Floor Unit No 2238, Brigade Gateway Campus, 26/1, Dr. Rajkumar Road Malleshwaram (W)
560055
Bangalore
+91 8067935355
indiasales@schaffner.com

Italy

Schaffner EMC S.r.l.

Via Ticino, 30
20900
Monza (MB)
+39 039 21 41 070
italysales@schaffner.com

Japan

Schaffner EMC K.K.

ISM Sangenjaya 7F
1-32-12 Kamiuma, Setagaya-ku
154-0011
Tokyo
+81 3 5712 3650
japansales@schaffner.com

Singapore

Schaffner EMC Pte Ltd.

Blk 3015A Ubi Road 1, #05-09, Kampong Ubi Industrial Estate
408705
Singapore
+65 63773283
singaporesales@schaffner.com

Spain

Schaffner EMC España

Calle Caléndula 93, Miniparc III, Edificio E El Soto de Moraleja, Alcobendas
28109
Madrid
+34 917 912 900
spainsales@schaffner.com

Sweden

Schaffner EMC AB

Östermalmstrorg 1
114 42
Stockholm
+46 8 5050 2425
swedensales@schaffner.com

Switzerland

Schaffner EMV AG

Industrie Nord
Nordstrasse 11e
4542
Luterbach
+41 32 681 66 26
switzerlandsales@schaffner.com

Taiwan

Schaffner EMV Ltd.

U-Town
20 Floor-2, No 97, Section 1, XinTai 5th Road, XiZhi District
22175
New Taipei City
+886 226975500
taiwansales@schaffner.com

Thailand

Schaffner EMC Co. Ltd.

Sathorn Square Tower
Room 3780, 37FL, 98 North-Sathorn Rd, Silom, Bangrak
10500
Bangkok
+66 621056397
thailandsales@schaffner.com

United Kingdom

Schaffner Ltd.

1, Oakmede Place
Terrace Road
RG42 4JF
Binfield
+44 118 9770070
uksales@schaffner.com

United States

Schaffner EMC Inc.

52 Mayfield Avenue
Edison, New Jersey
+1 732 225 9533
usasales@schaffner.com

To find your local partner within Schaffner's global network schaffner.com

© 2022 Schaffner Group

The content of this document has been carefully checked and understood. However, neither Schaffner nor its subsidiaries assume any liability whatsoever for any errors or inaccuracies of this document and the consequences thereof. Published specifications are subject to change without notice. Product suitability for any area of application must ultimately be determined by the customer. In all cases, products must never be operated outside their published specifications. Schaffner does not guarantee the availability of all published products. This disclaimer shall be governed by substantive Swiss law and resulting disputes shall be settled by the courts at the place of business of Schaffner Holding AG. Latest publications and a complete disclaimer can be downloaded from the Schaffner website. All trademarks recognized.